

Standard Details:

Standard Notes:

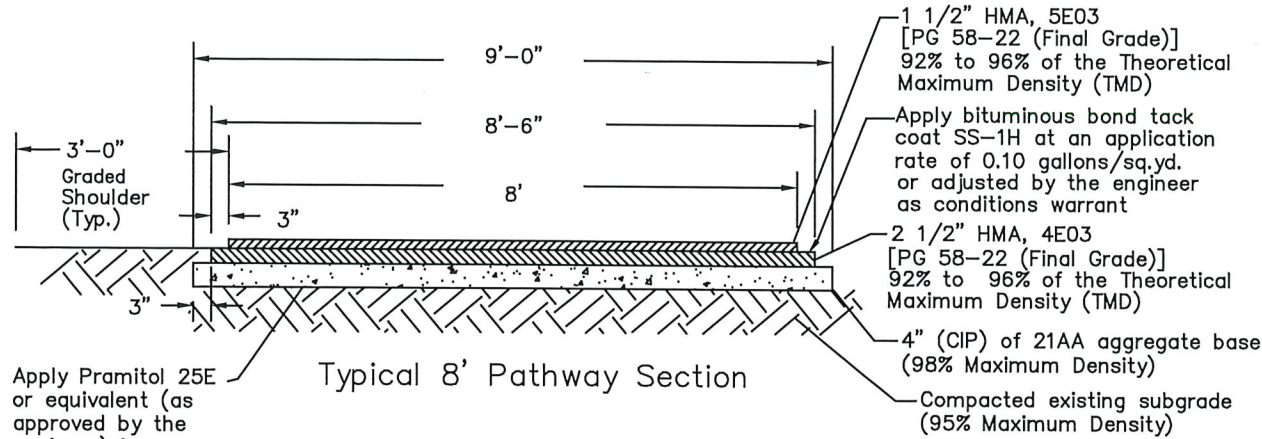

1. Maximum grade of 8.33% along pathway (less than 5% is recommended).
2. 1% cross slope (i.e. super elevation) for drainage off and away from pathway and graded shoulders (2% maximum cross-slope).
3. 60' minimum center line radii for pathway horizontal alignment.
4. Provide a minimum of 3' horizontal clearance and 10' vertical clearance from all fixed objects and the edge of pathway surface. Relocation of existing objects (i.e. mail boxes, signs, etc.) shall be considered incidental work items.
5. Pathway ramps shall be constructed in accordance with MDOT standard detail R-28 Series and shall have a minimum clear opening of 8' wide.
6. A clean saw cut joint shall be provided wherever new pavement matches existing pavement (incidental work item).
7. Utility structures shall be adjusted in accordance with the City of Rochester Hills standards and shall match the proposed grade of the pathway.
8. Pathway shall be 6 inch thick HMA or concrete through residential drives and 9 inch thick HMA or 8 inch thick concrete through commercial drives.
9. Pathway asphalt shall be paid for as "Shared Use Path, HMA" when part of public improvement project.
10. Ramps and landings shall be 6 inch thick concrete.
11. ADA detectable warning plates shall be preformed and brick red in color. Acceptable products included ADA Solutions, Inc., Armor-Tile, ej, or approved equal.

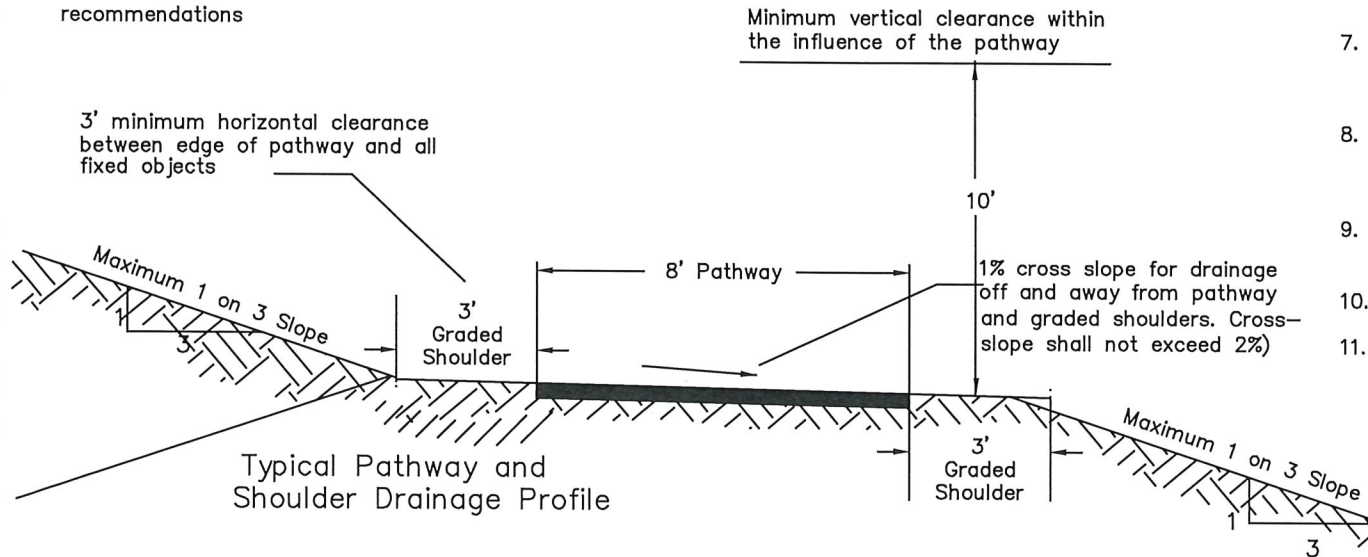

CITY OF ROCHESTER HILLS
STANDARD DETAIL FOR:
Pathway Details:
Hot-Mixed Asphalt Pathway
Construction, Extensions and Relocations

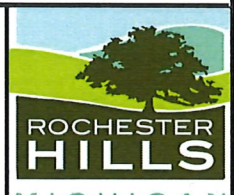

DRAWN BY: B. SMITH	PLAN DATE: 8/28/1996	REVISIONS: 4/12/2012	2/25/2014	8/22/2018	
APPROVED BY: PAUL SHUMEJKO, P.E., PTOE CITY TRANSPORTATION ENGINEERING MANAGER		2/25/2016	11/12/2019		
NOT TO SCALE				SHEET 1 OF 1	